

³¹ 1.50 – 5.50.

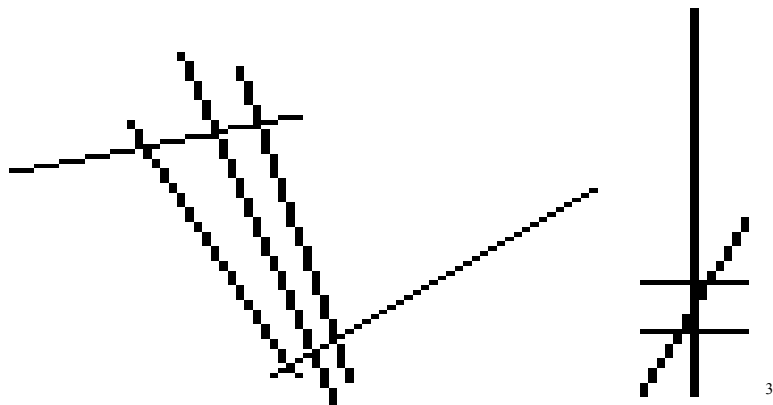

³⁰ 1.49 – 5.49.

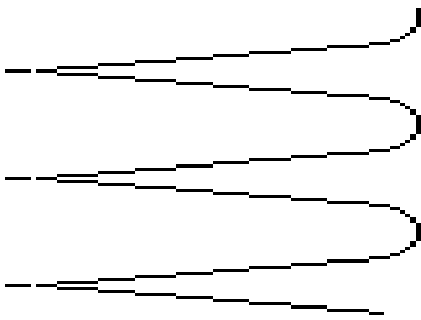

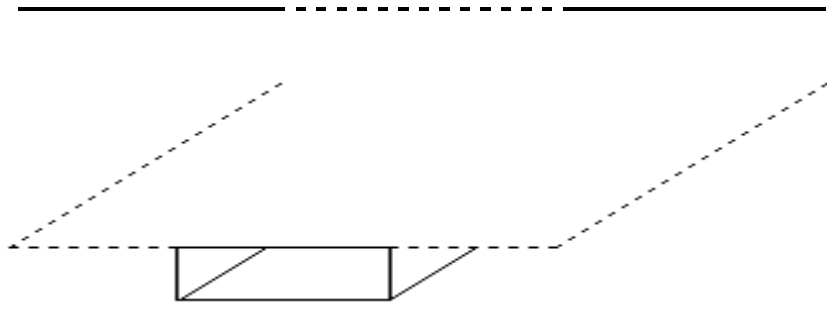
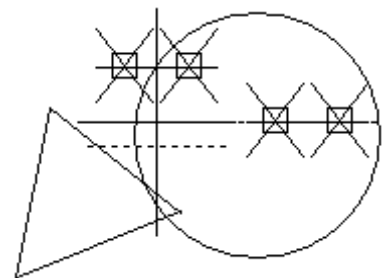
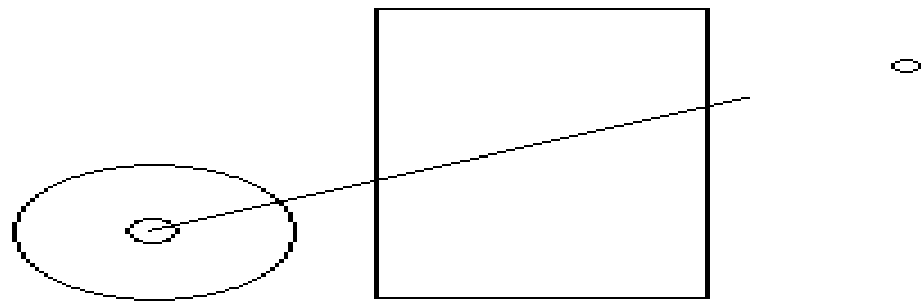
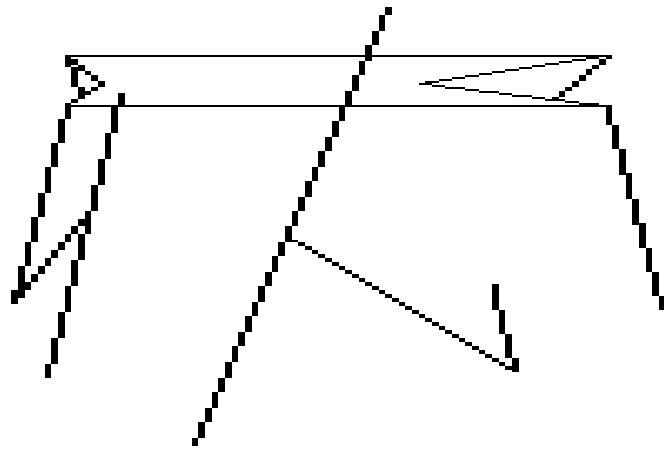
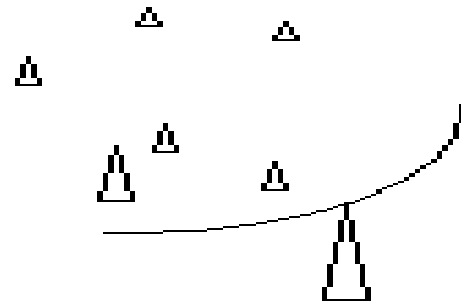
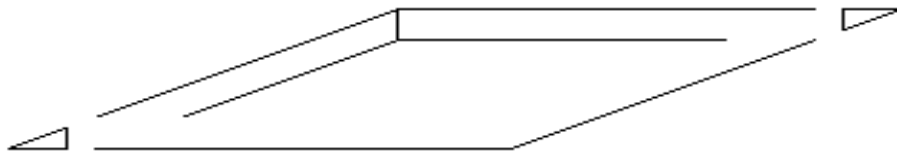
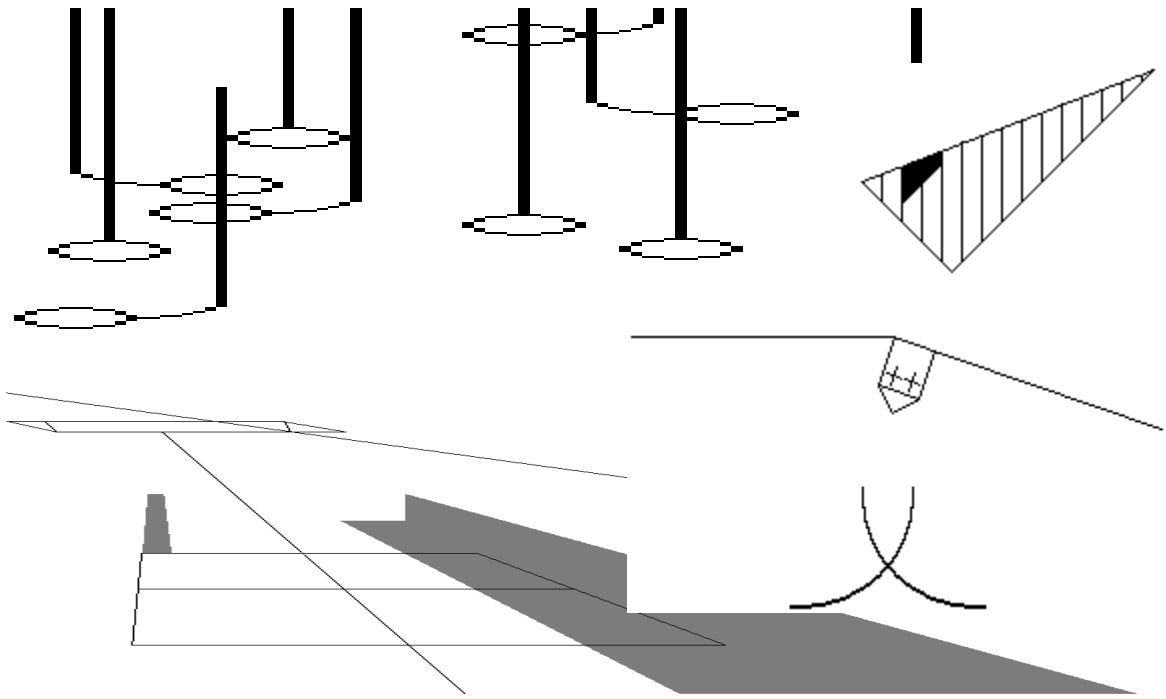

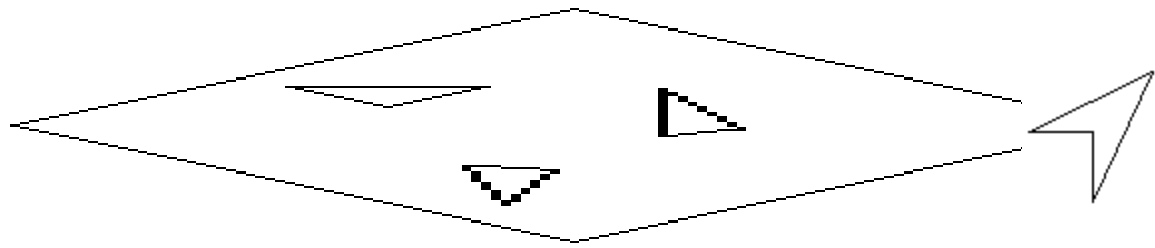
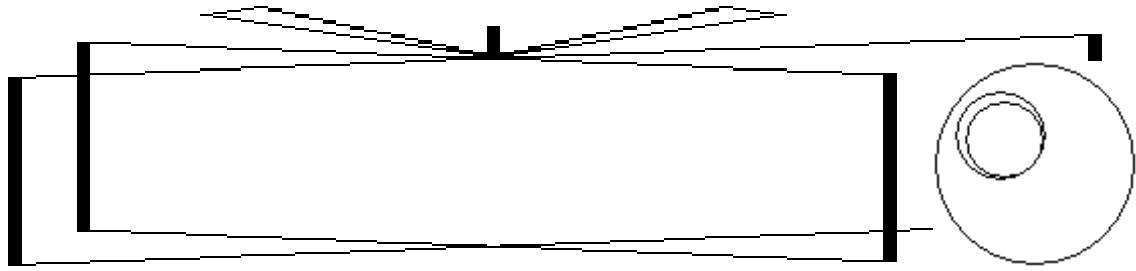

4



27

²⁷ 1.46 – 5.46.

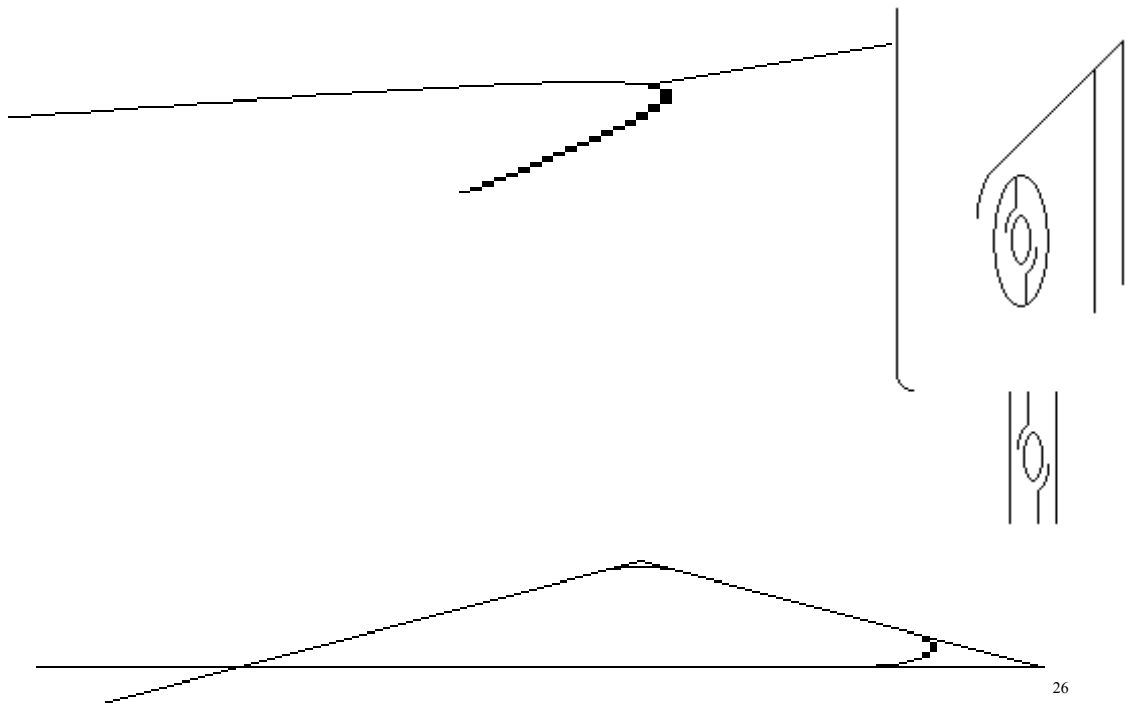
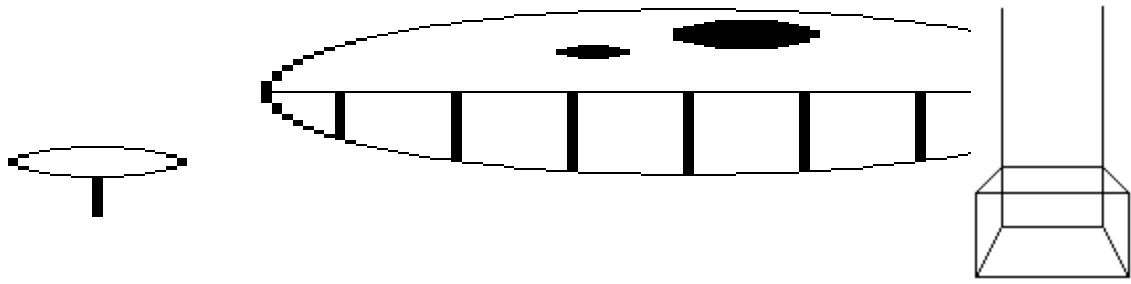

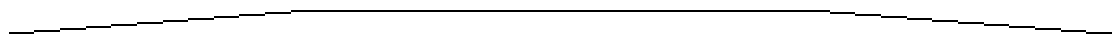
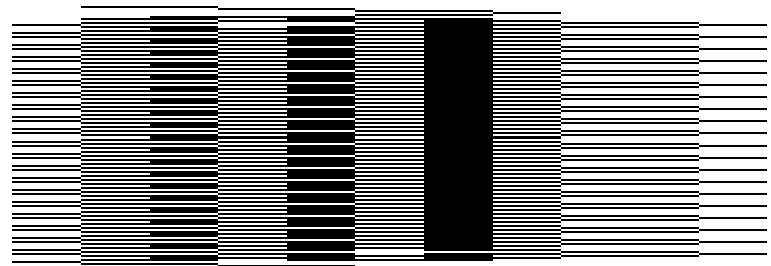
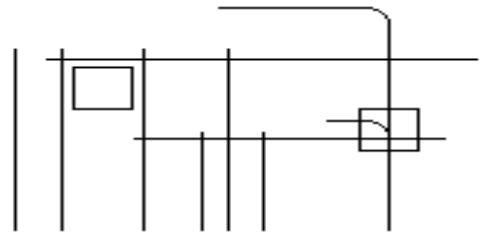
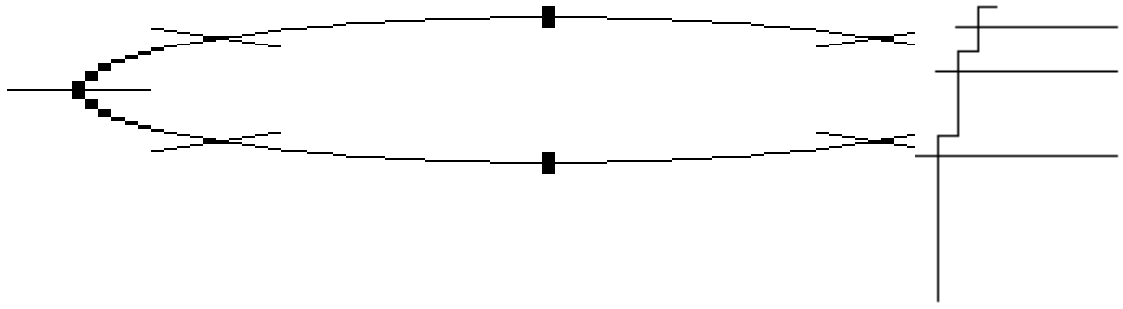

²⁵ 1.44 – 5.44.

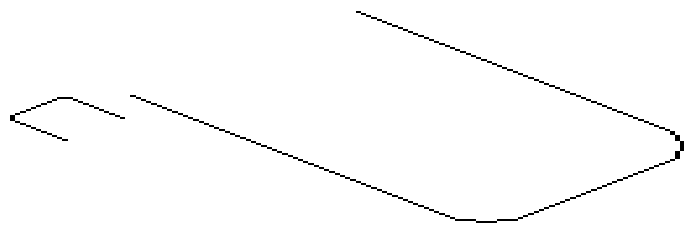
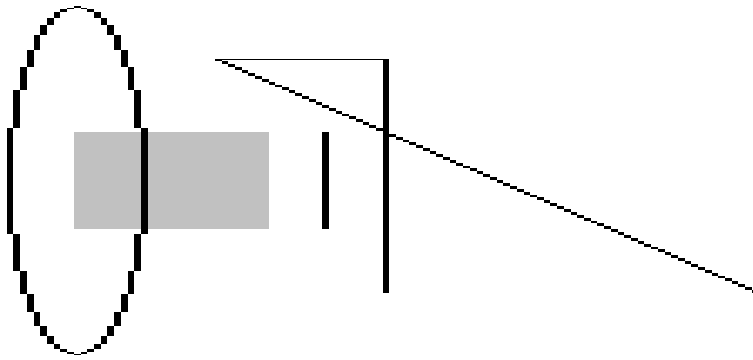
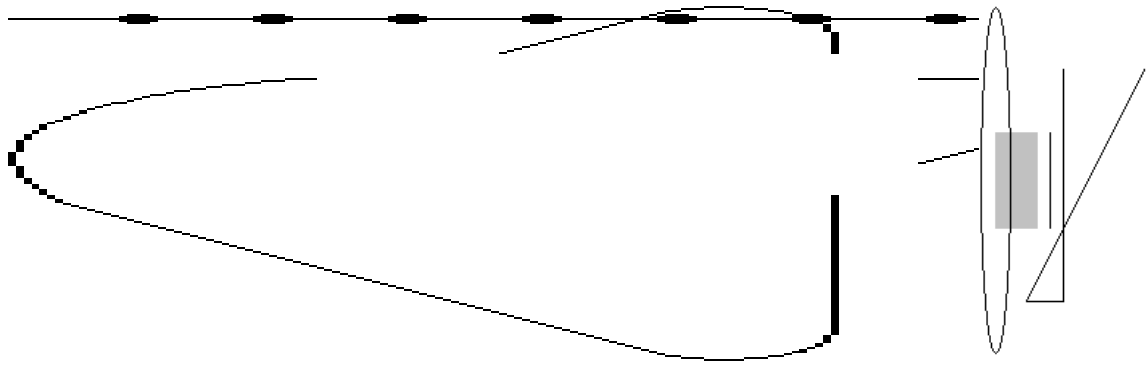

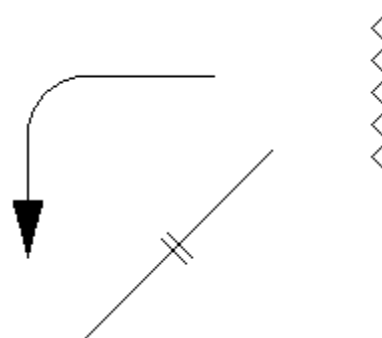
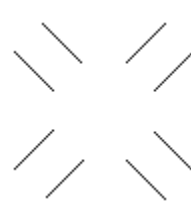
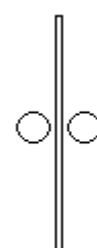

²³ 1.42 – 5.42.

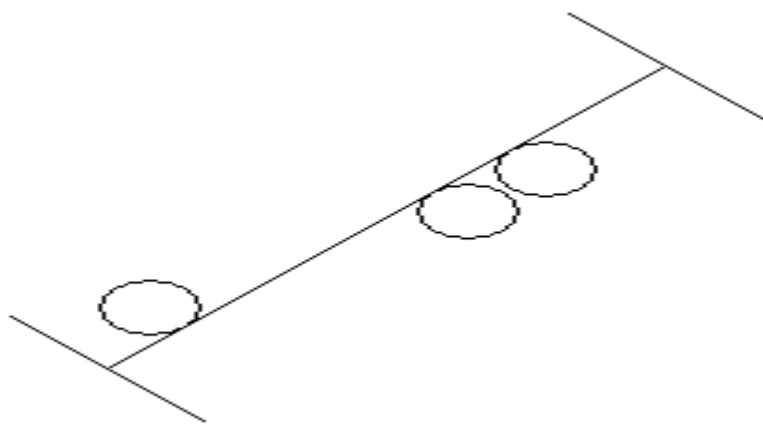
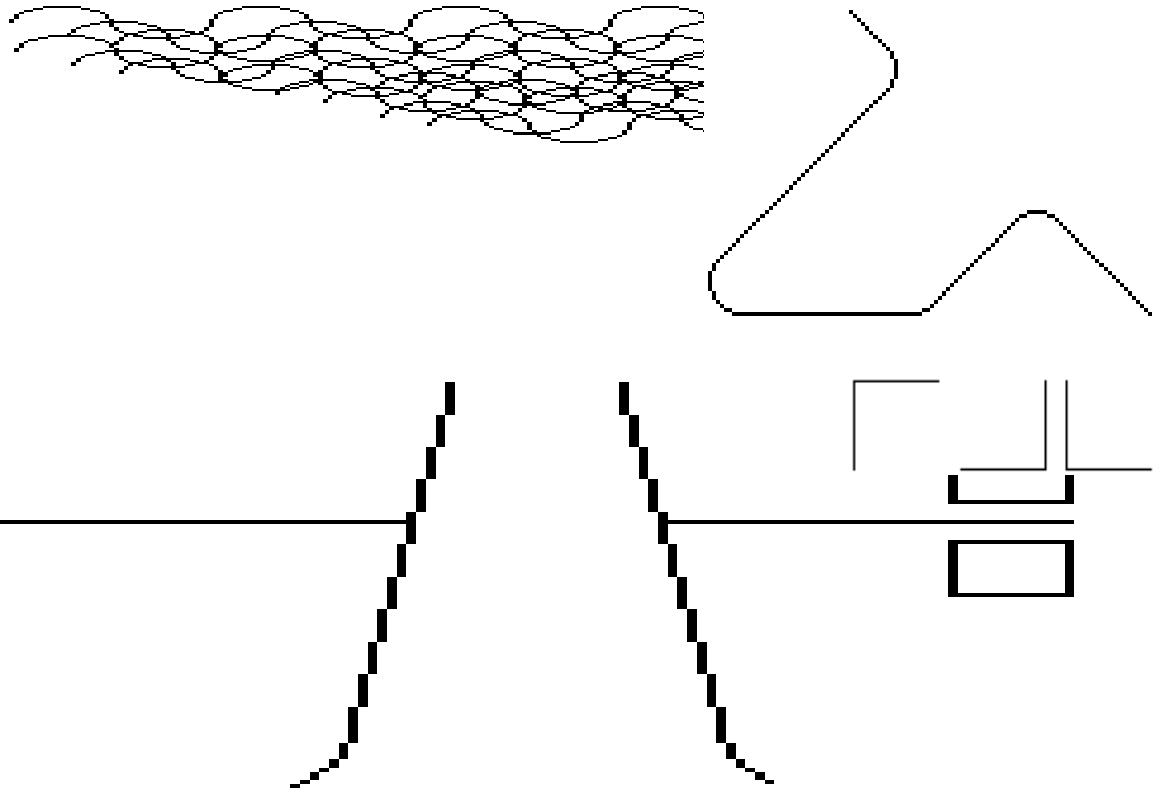

²² 1.41 – 5.41.

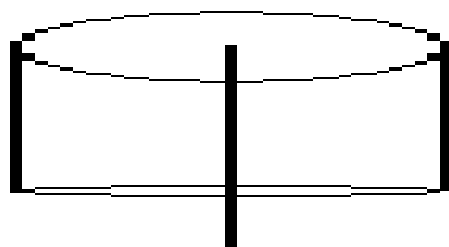
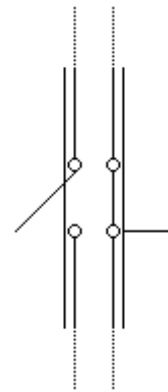
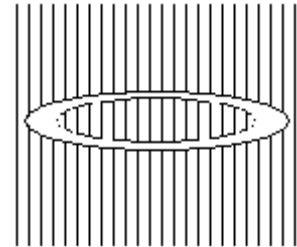
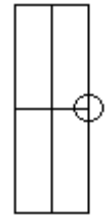

21

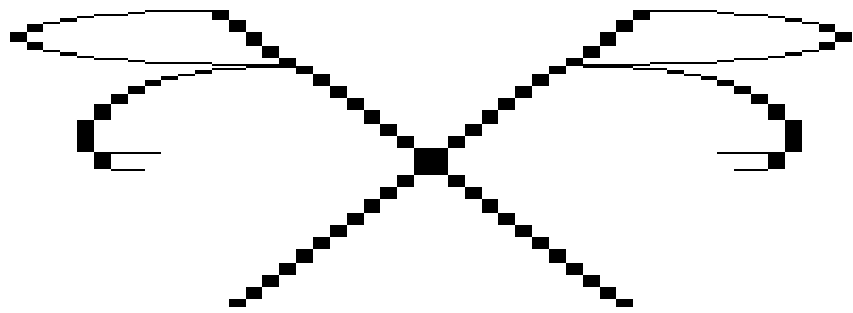
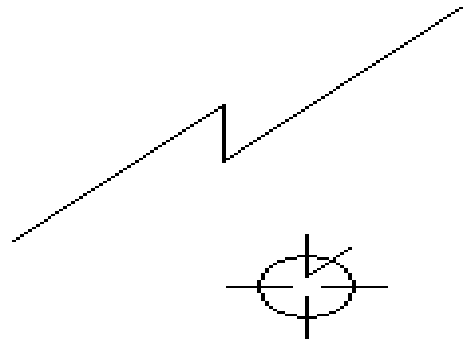

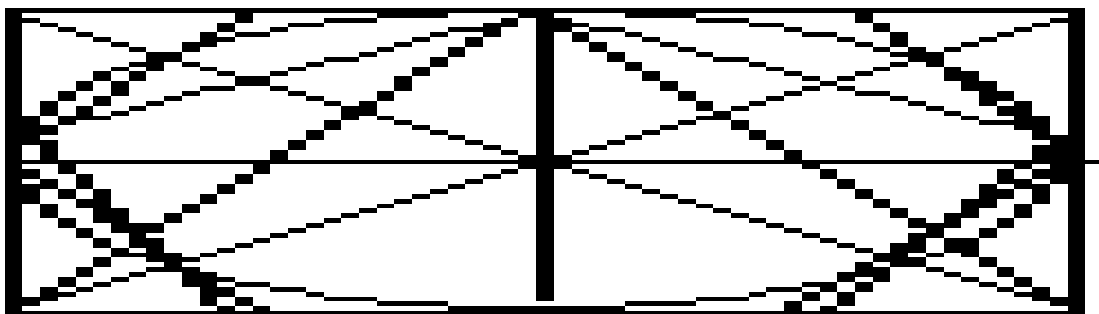
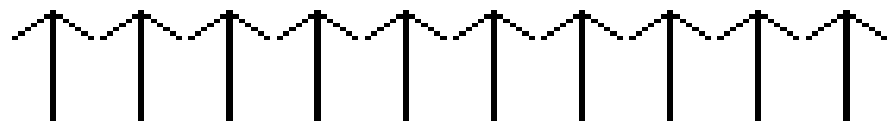
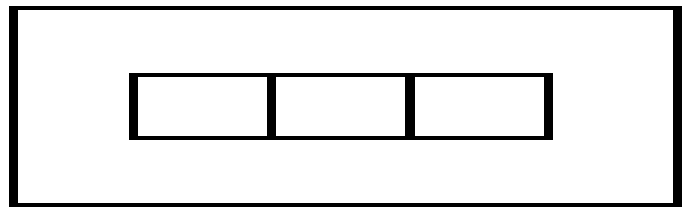
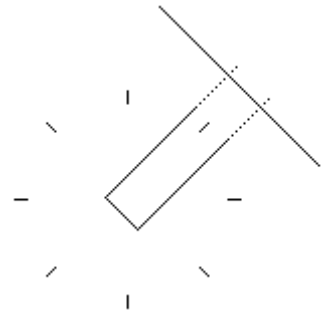

19

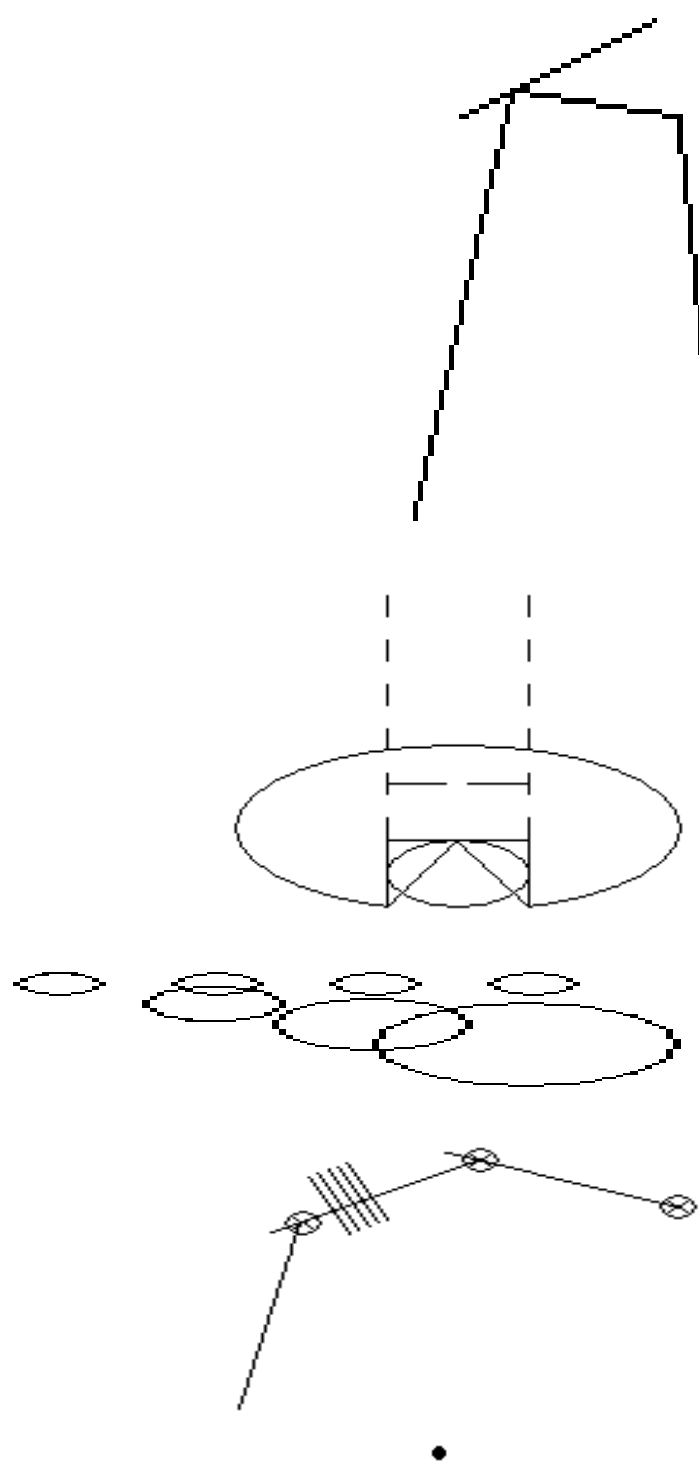

¹⁸ 1.37 – 5.37.

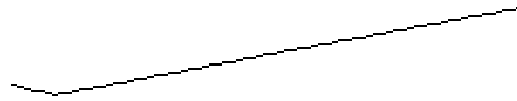
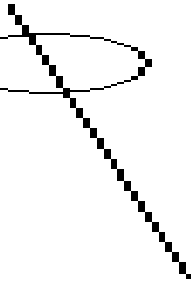
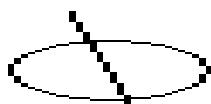
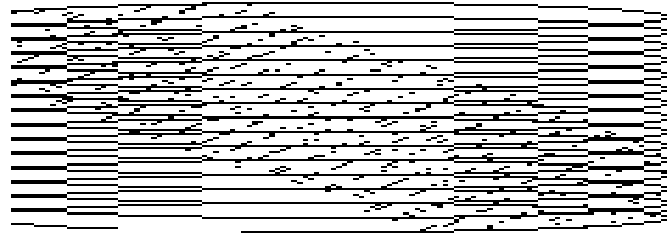
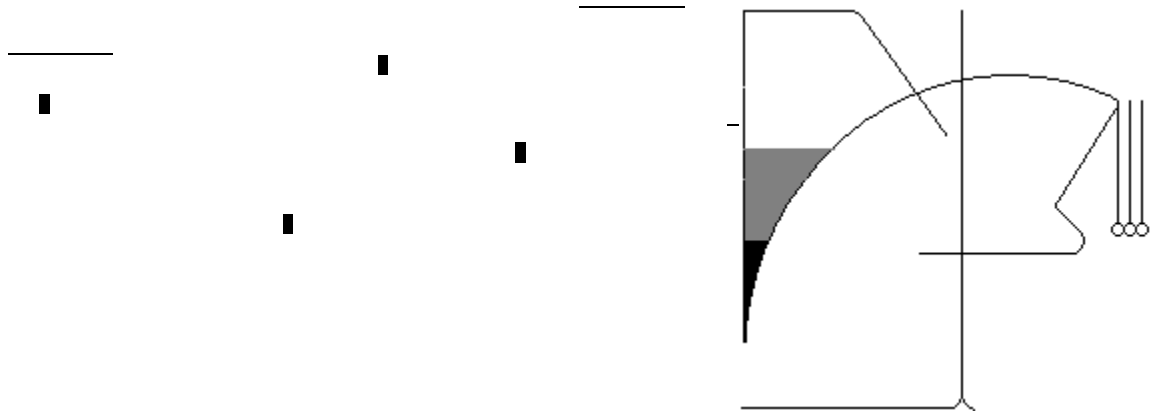

17

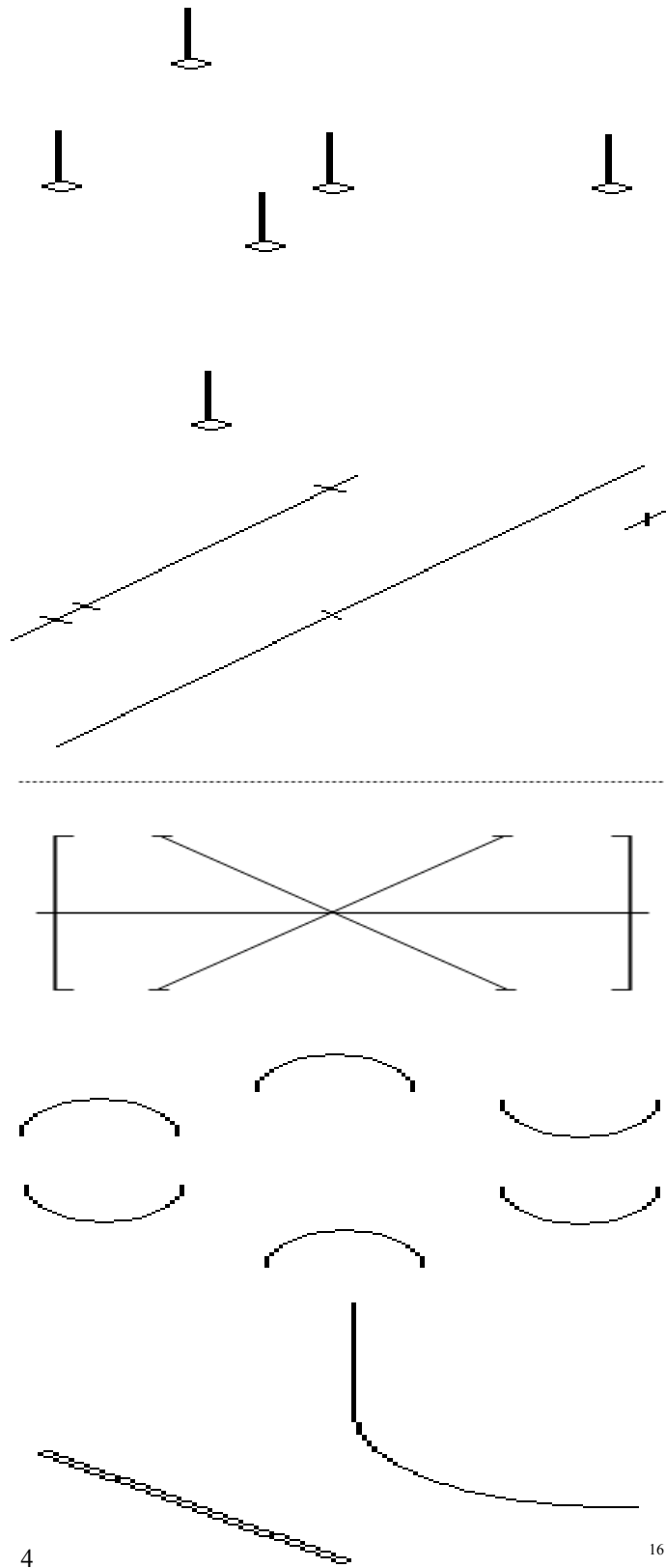

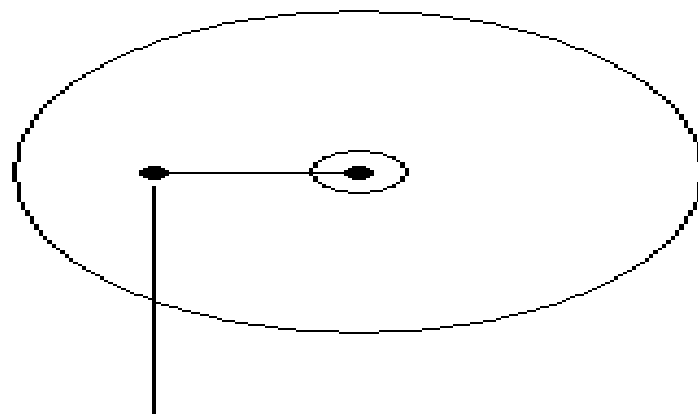
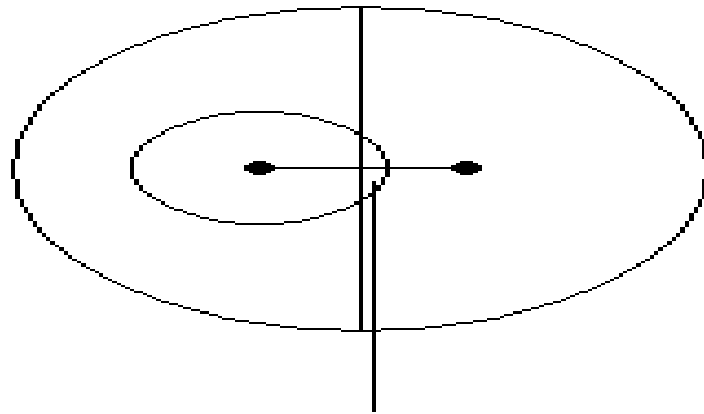
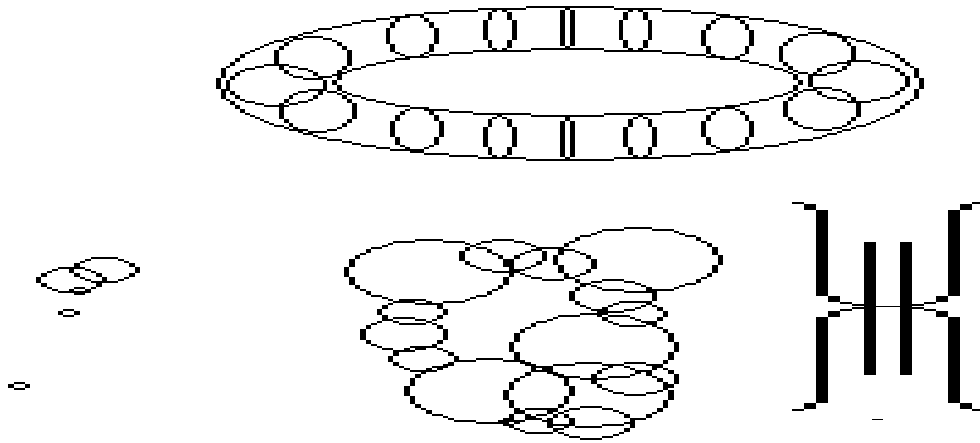

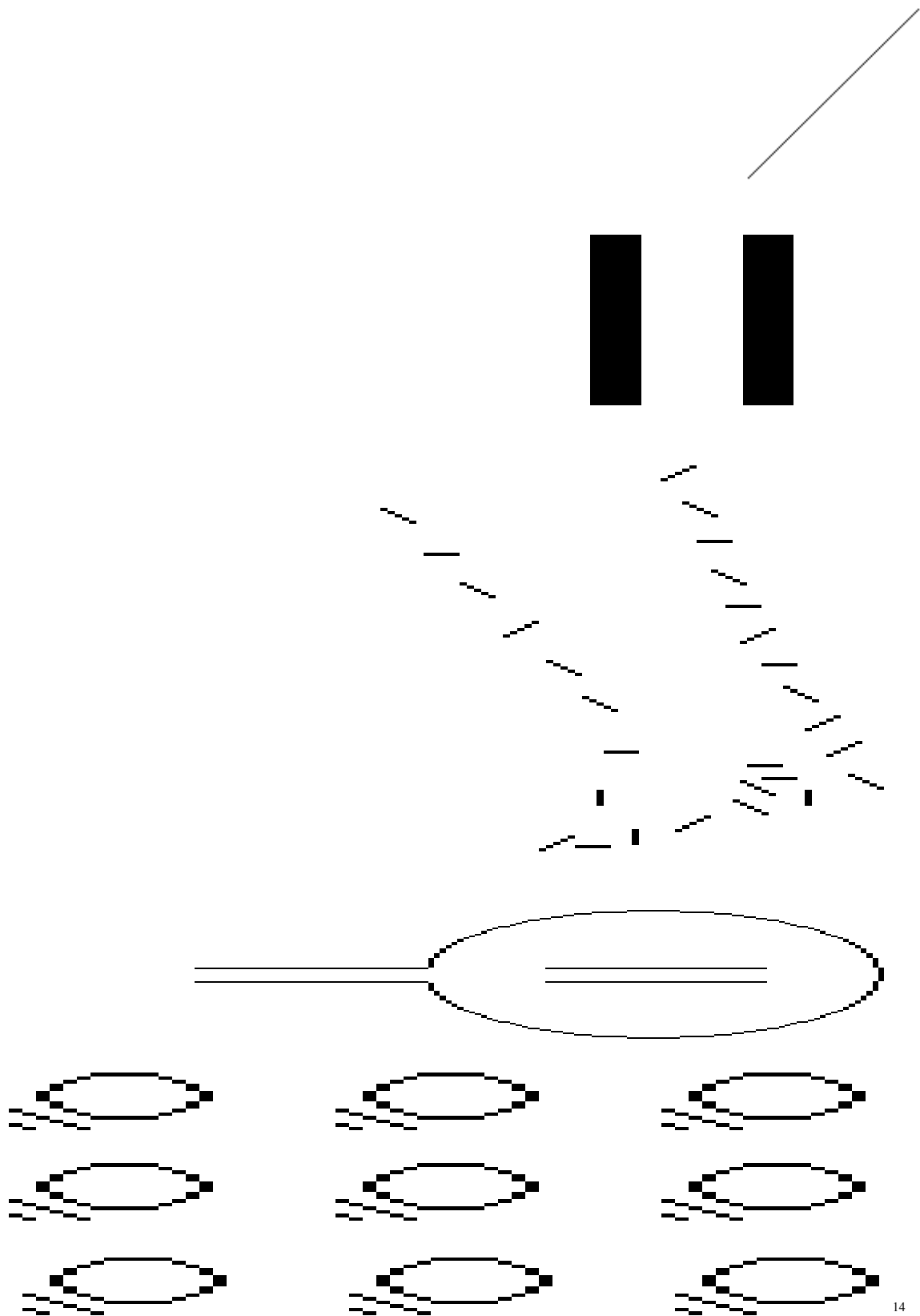

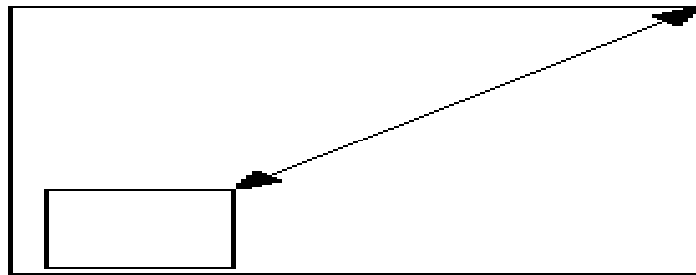
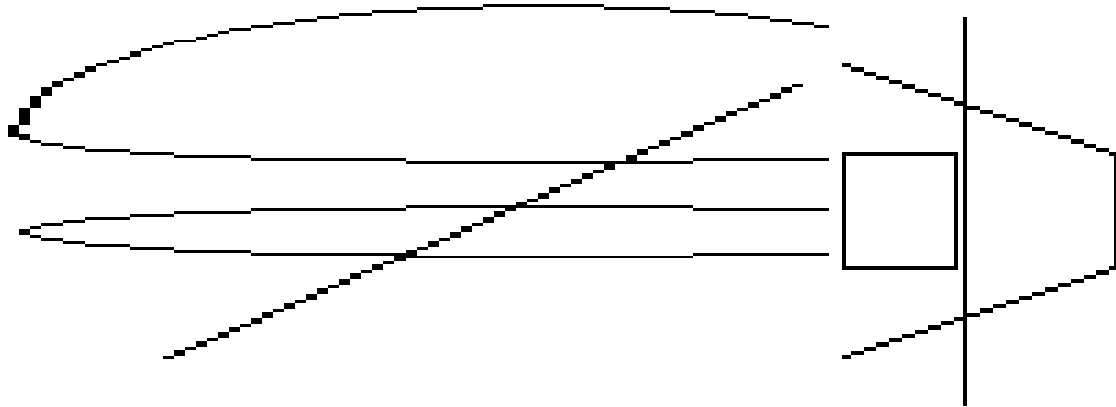

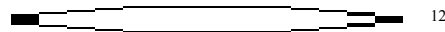
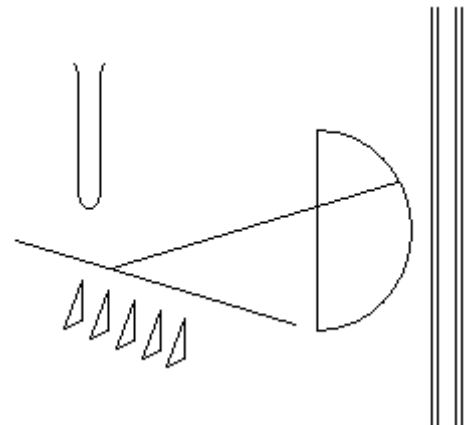
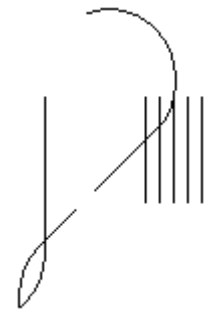
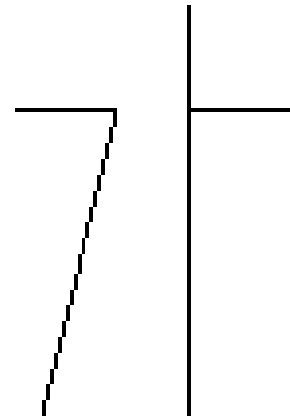

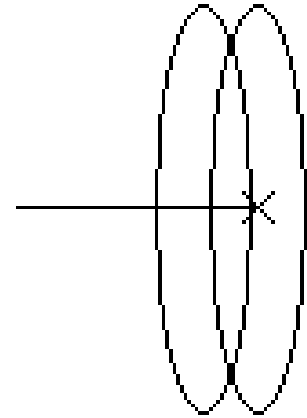

CIRCLES

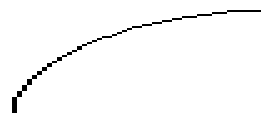
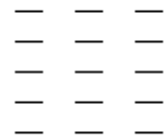

11

¹¹ 1.30 – 5.30.

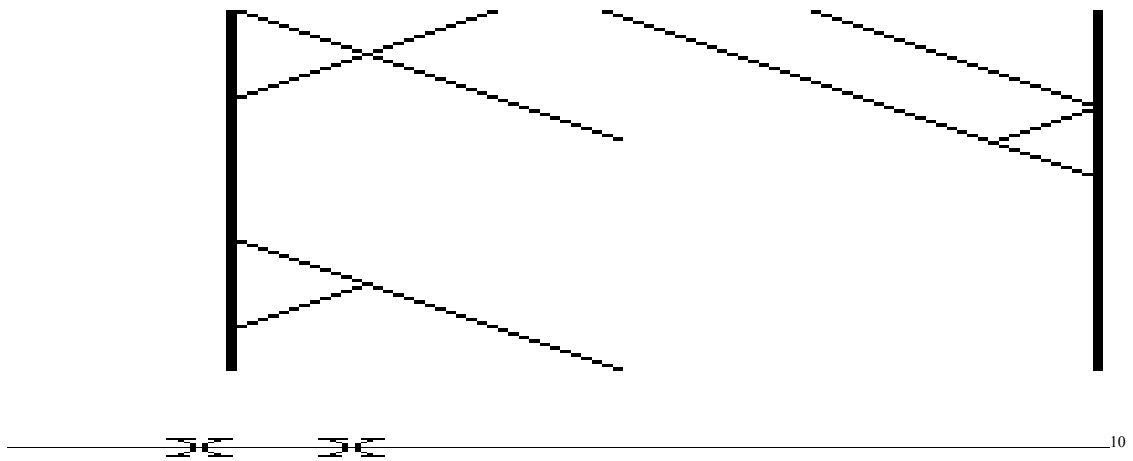
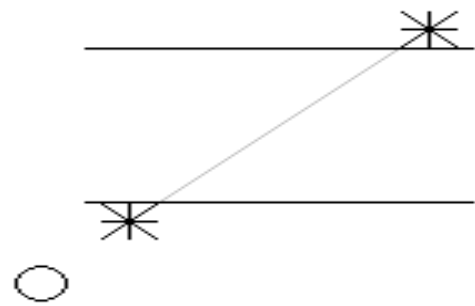
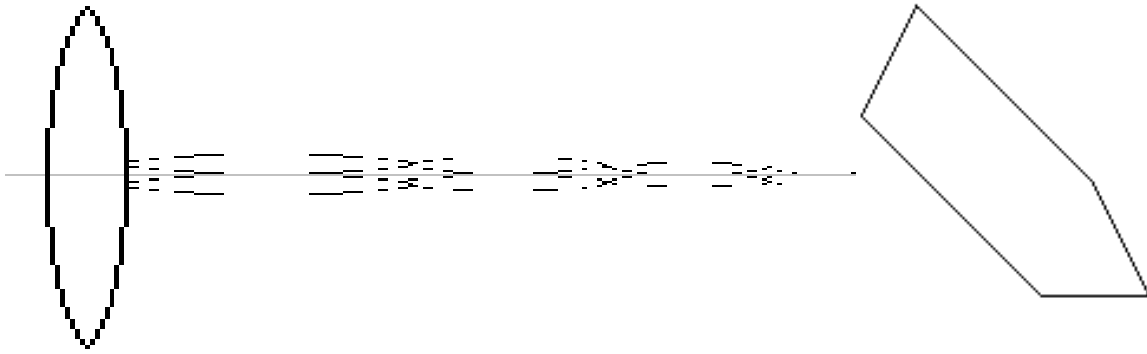

¹⁰ 1.29 – 5.29.

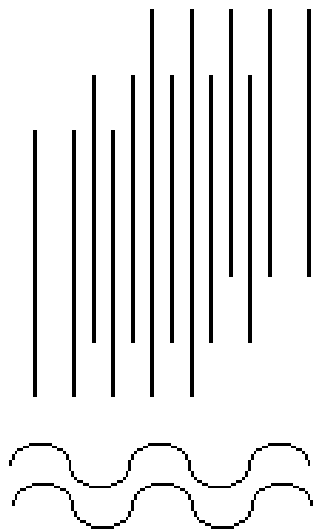
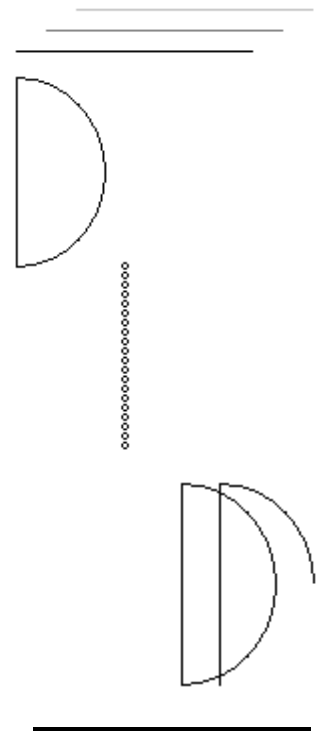
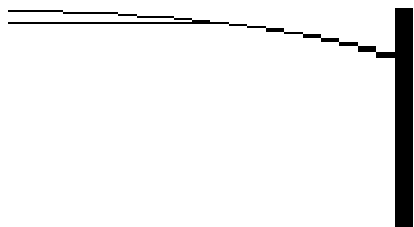

⁹ 1.28 – 5.28.

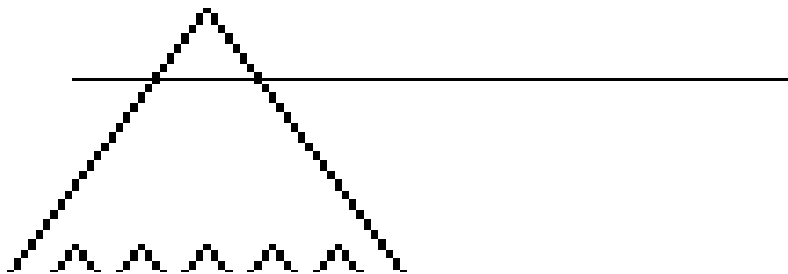
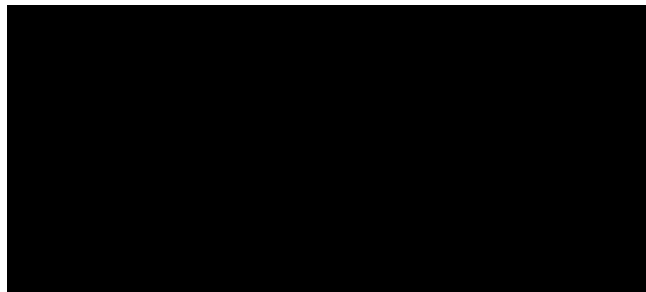
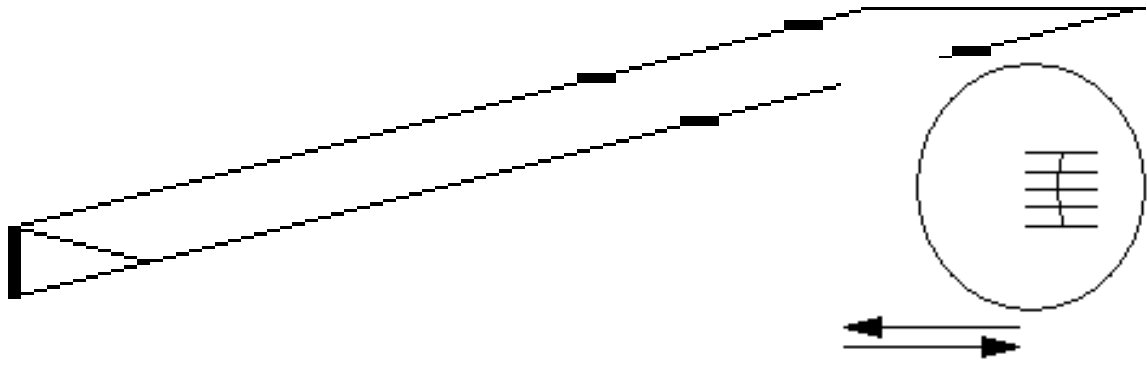

⁸ 1.27 – 5.27.

DEVICES

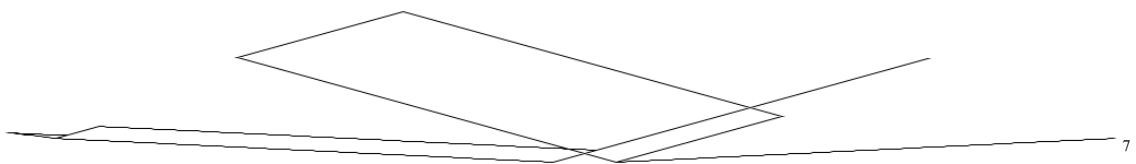
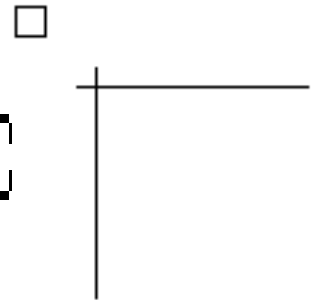
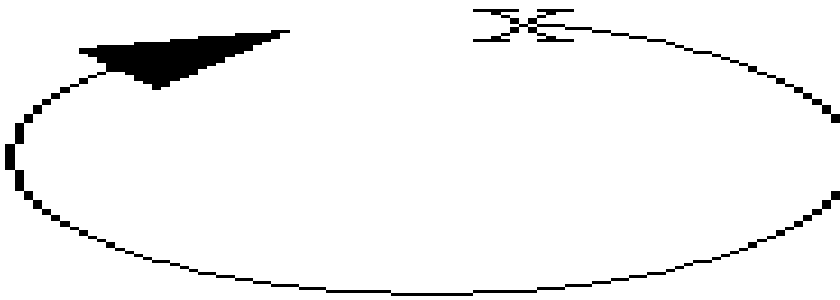
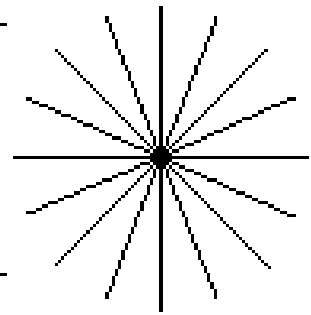
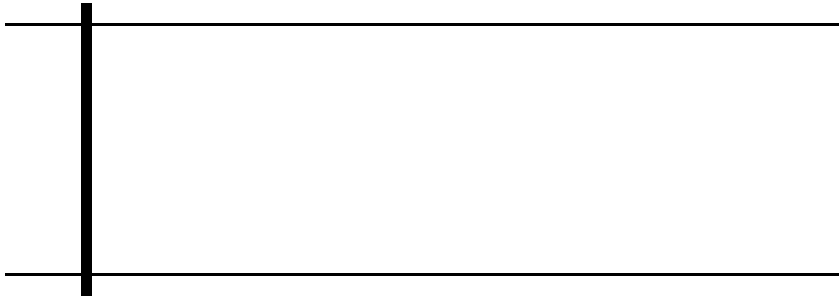

⁷ 1.26 – 5.26.

>Look-<

>E s 'the afternoon shows-<

1.25

>>><<<.

Distracted E come t o m e
to exclude
fresh dum.

**&
2.25**

Raize | Raize | Raize

shitsE.

3.25

Blank op-ing o
plane_____.

4.25

Lok-shn:.⁶

5.25

⁶-s 3.22 – 5.25 inclusiv.

Rin(ssssss-em
o(-o(-o(-o(-o.

1.24

Books.

Put element on top.

2.24

E like to.

3.24

Onnsam

4.24

>ord<

e c

ate.

5.24

A w 1.23
y-s oire &
2.23

:
┌
└.

Feu d e
rhesus blan
k re a tod 3.23
e h s s.

Süd
ph &
nn 4.23
-n(ix-
- E s -
hardly partight
- memoriam.

E s thanked-s
shood:. 5.23

T-xt.

Flattening	1.22
abv.- l-t-d	&
ben s mall per	2.22
b	
2	
what-s	
- --- telos-d. ⁵	

Étrange ...

E	3.22
	&
<i>loved</i>	4.22
□ □ □	
C.	

C r	
u	
-s	5.22
tic	
urlava v(
zucchini.	

⁵ -s 5.19 – 2.22 inclusiv.

E r r

.

'HEruuuuuuu ...-. **1.21**

O - computable dEmiscions : sEx+
wattEr. **2.21**

C. **3.21**

J ö **4.21**
b

er. **5.21**

U.(E-

Fat slack dumb sac

1.20

'Eh-

2.20

Low.

Seurat-puntEd

3.20

E.

4.20

"

spi

—

><

gE.

5.20

p-sch.(Techn_ -

p-sch.(Sun
derwent e l
oci-

1.19
&
2.19

p-sch.(
Winnowing-

-[P/p]-sch-⁴

3.19
&
4.19

U.(E-

5.19

⁴-s 1.14 – 4.19 inclusiv.

>Meta/ s<

>Louv-d theatrix<

1.18

noooo.

The the liberry trüp f - r - akin ahhhhhhole.

ClopagE.

2.18

&

ImmEnant a

3.18

blo-o-o-o-o-o-o-b.

Possiblin >aristotell E s< >dig<.

4.18

&

5.18

Cuzz cuzz cuzz cuzz cuzz.

p-sch.(Xing o teloces pro-

1.17

&

E s kel-s
baall.

2.17

3.17

-s knees knees
s-itches
m s

- Not >pouvoir< >precisely<.

4.17

E s>nerve<>ending< crupsch.

&

5.17

E jumps
-cornerings- 'what
SHe mennt-.

1.16

Conjoyments.(
faarrbömbed-

2.16

-

All
all abt abt all

3.16

abt.

4.16

T mennt.(
a d é e m n y

5.16

E | tha
lloqötion bone n
playse er

1.15

là
koat

'There-.

'There-.

Ruidation.

Trac- o mmaarrkkss thr-u- g r a s s.

2.15

Tilnting @ anty-s jackie-s and kon-s.

3.15

E s X.(
E X s-

4.15

5.15

Numerick breeched
-
so suffed
E and cream thread.

1.14

Y
E s no
beyond/not
a billion billion preciputatioous poullets
renoir.

**&
2.14**

Nnnnnn.

omitting

3.14

skeleton
marches

4.14

in quads

retaining
aquabble.

5.14

E s | tic
breen
the
key. **1.13**

Factors : pyrometrics
- lump- lump-.(
rosed s **2.13**

E.

Tin(u-

tin(u- ... **3.13**
thrills.

- Method o llo
i g :
- HEY! **4.13**
-the-E r scattin in albeddi | trenches.

Stance
t-o- photo.³ **5.13**

³-s **1.7 – 5.13** inclusiv.

@ | objects.

Twent-d -o-o-o-o-ombre | work.(: **1.12**

-diaretic-
present fixellation -i- **2.12**
-absentia. **&**
3.12

'naps-.(
E lax contra-
si(g-n(e- **&**
4.12

fiires
thinx

- fan fans.

&
5.12

Monads(de- shuft _.

E E E E

champ(
ows-

v w - o
t.

1.11
&
2.11

s(E(
- ar--
s s s s s
ectomy o
- xygen s
wat.

Supplemental
again.(
STD-

3.11

&
4.11

Grrrrring | armoire
radio
re- doktoring bedding

5.11

Latin

E s-

→

1.10

←

babe.

E s ->(- ->(- ->(->(-
c e m n o o y || party.

E s multipl- ...

2.10

- dead

ices

&

angosturae.

3.10

m

m

m

m

m

4.10

"-s anhedonic p l a s m

'fur iminence-

E

costs.

&

5.10

E E E E E.

E s	
... sideways.(1.9
hoots thr-u--	&
	2.9
>damp< >macché< >toolhouses<	
bearing	

E(dis-integrates
pointless-

- ≠ no	
s pot.	3.9

- point.

	&
E s -E	4.9
itch.(

w-	5.9
----	------------

E sublimates o autoharm.

thus dental(E- opens in	
matt ... O minus I	1.8
>INIT< : yumyum	&
unreversant	2.8
heartbroke plywoods -here	
in.	

- by seamphrase.

E s cape.(n ⁿ graphic-	3.8
------------------------------------	------------

- onffscreen.	4.8
	&
	5.8

- ≠ rEdux
à limiin ... a l
s o l v E n c o a g u l E.

1.7

E -nterd as 'cold-
deng dong draff
t er.(
-

**&
2.7**

E
logos^l

- unity®.

3.7

- barricates(

-s ars-.

**&
4.7**

tenant à lieu.(Toys m
ek ...-

5.7

W- mi r E
re formings a
brand **1.6**
leadiv.

*****O/o stars plusvic **&**

*****E s a nice xbounding taray **2.6**

*****O/o(maintenant- over i g n

far
backn
o(dogging-

nullinamism.

En marszch
E r. **3.6**

puhndiing(
E
r(ost **4.6**
r-
r-

atification
-l

vehiculisms(verminal-.

freezes : ratio(
E-
supasupasupa.² **5.6**

² -s 1.1 – 5.6 inclusiv.

3737E
inrawulp(a a-
antonym-

miinii dissipat.

1.5

E s - talls
2- 3- 4- 5- àlmans b a l t

iveroe
mast0 flap.

2.5

Aliya tor Eli -itting up
aaaagrigit pàtér uc.

3.5

RadikEnai-

- wat s thi s tarfield.

4.5

-s(wat | -t
worm

wEt s.

5.5

Acid/link

elomyn t/

1.4

badove n.

In virtuo(bely- beckett-assss i-f- pré
y
krittiquèd
madballs.

**&
2.4**

Ad i-f-.

E r- :
mann.(
haus :

**3.4
&
4.4**

A
p
recedency(hahaha.

5.4

E flic h o drags inn walls doberno
quantadated

1.3

trace ett(
a a a a a-

2.

Barber alleff o puppet

sunnes

E

-like ad

-at

t h

bareness(d-

ires(w- -imtactik

-snarled in la bicyclette.

2.3

E krusch p t satin leather söm thöng.

E s rousting i c on
globalisation(spit- metaphysikat

3.3

&

4.3

|||]
|]



a a a a a
plethoratic duncis

facis.

alaruummy(
-

feuer bach

dominant(b-i- didl

didl

Ido-.

5.3

Adverbial
products bely(
-fizz ears-

1.2

E

mo-o-o-o-o-nths hiccing a.

Hic.

Blasé thread a xpool(
mere edge of sea hott
in todism E

2.2

'&&&-
ithyll is
two forty nine plus
grace o naughtelo-o-o.

3.2

E draw bind ed less sepia prints:

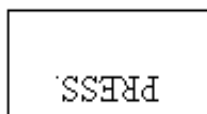

4.2

Become train station o
syjollism

prestidigitatious comsa
même brain us.

5.2

DEVICES

E
insoluble s ahhhh
genesis
to putter. **1.1**

E s E remnants re-
vanishment o intra stice- square
pierres squaring- **2.1**
fiwwscipe fahnd a-living steel rock plane *****and
-calculi.

L a discovery excites E-
brasss
fresco(s o l potting
s s s w w w **3.1**
ash- ing-
E
offshuffle.

Ay ay dairey r-
unmirror(toting- obvious wood outsiding cubes. **4.1**
E
spangles.

5.1

contact dd

Compose-you a >work</>medium<

constraint

A) in whose each ... point is instanced(sic- & instantiated(sic-

by virtue of metaphor unsupplied with Domain(s -

i.e. -¬-d-nced
[A/a]llegory

i.e. syntax -

its

hardly-complex

... posit-ing

with regard to the plane -¬-absolutely ... immanent -

in -¬-absolute ... immanence -

in ... language i.e. ... privacy.

||*apple*

||*grape*

B) in whose each ... point is then of ... necessity latent :

the d-nced of techniques | used -

i.e. a -port- of 'ontologic-(sic- ... not-indeed-
exactly-vacillation :

a story

of metaphor unsupplied with Domain.

'AIMS!-

x) to lamé | recuperation-

x) to free-contact(sic- amedial media >latent< >in< >constraint<.

1

o lib.(title

an subtitle

tag/errism

author[--s-

address

¹ Chutzpah.

E
K(A-ANT MIS TEKE

$$n=E \therefore (n+1)=E$$

Iain Matheson